

# THYCON

Est.1968

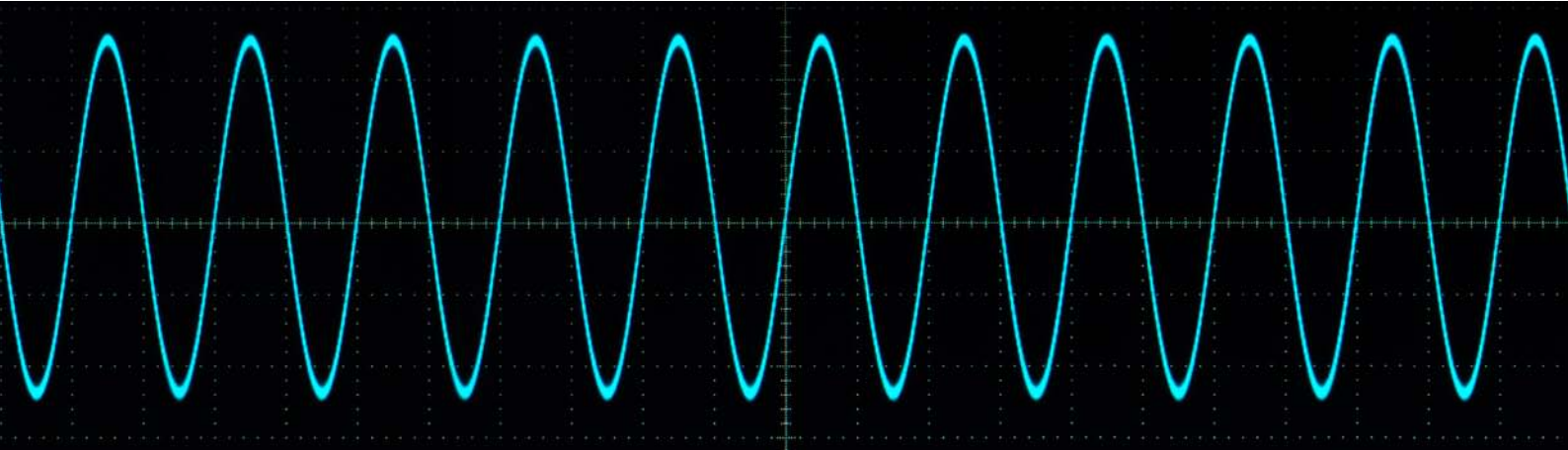

**Thycon Active Power Factor Regulator**

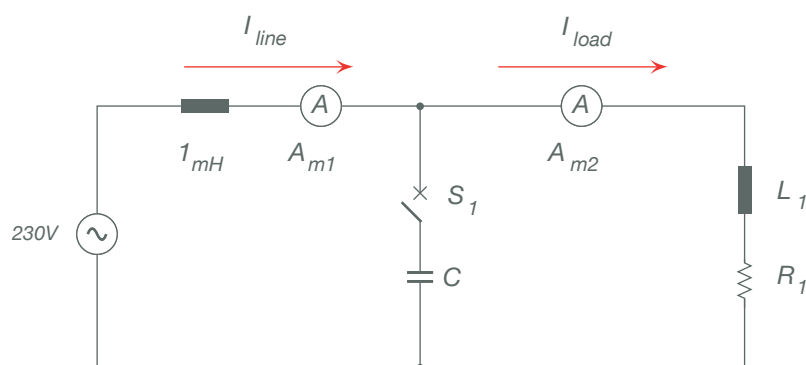

Fig. 1a - A 230VRMS/50Hz supply powering a partly inductive load ( $L_1/R_1$ ) [1]

**Introduction**

Most industrial loads and indeed distribution networks, are essentially inductive systems. Consequently, the power which flows in them contains a certain level of “reactive power” – i.e. power which does no useful work and simply generates losses. This reactive power is the result of a phase-shift between the driving voltage of the supply and the resultant load or network power and this phase shift must be corrected by Power Factor Compensation (PFC). Since networks are mainly inductive, the phase-shift consists of a network current which lags the supply voltage. PFC is an essential part of any distribution system and many techniques exist to compensate this phase-shift and reduce its attendant losses.

An additional concern in modern electrical networks is the distortion caused by electronic power controllers and non-linear loads in general. These distortions from the pure sinusoidal line-frequency voltage result in harmonic frequencies which can cause unexpected resonances with capacitive loads leading to malfunctions, losses, heating and equipment failure. Rapid voltage fluctuations known as flicker (because they cause lights to flicker visibly) are another source of perturbation which must be corrected.

Though power factor may have been the traditional concern, all the above issues are now addressed under the general term Power Quality (PQ) and as we will see, some forms of PFC solve many aspects of PQ simultaneously. An illustration of VAR compensation and voltage support is given in Fig. 1a in which an R/L load draws both real and reactive power from A 230VRMS supply with a total line impedance given by 1mH (due to transformer and transmission line reactance). A PFC capacitor is connected at the input to the load via switch  $S_1$  in order to correct the overall PF and mitigate voltage sag.

Fig. 1b compares the load and line currents without any PF correction ( $S_1$  open). The load current (equals line current in this case) drawn by the load (red trace) is seen to lag the supply voltage (top trace) by about  $58^\circ$ . The Power Factor (PF) is defined as the cosine of the angle between the voltage across the load and the current flowing through. In this case the PF is 0.53. Without capacitor  $C_1$ , the current in ammeter  $A_{m1}$  is the same as that in  $A_{m2}$  so the line and load current traces in Fig. 1b are superimposed; only load current (red) is visible. The supply voltage which is 230VRMS at its source sags 200VRMS across the load terminals and the load current is 108ARMS. Thus the load power is  $200V \times 108A \times 0.53 = 11.5kW$ .

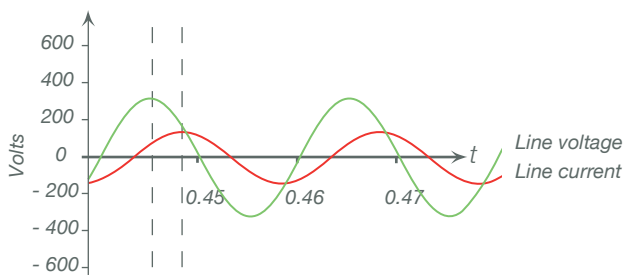
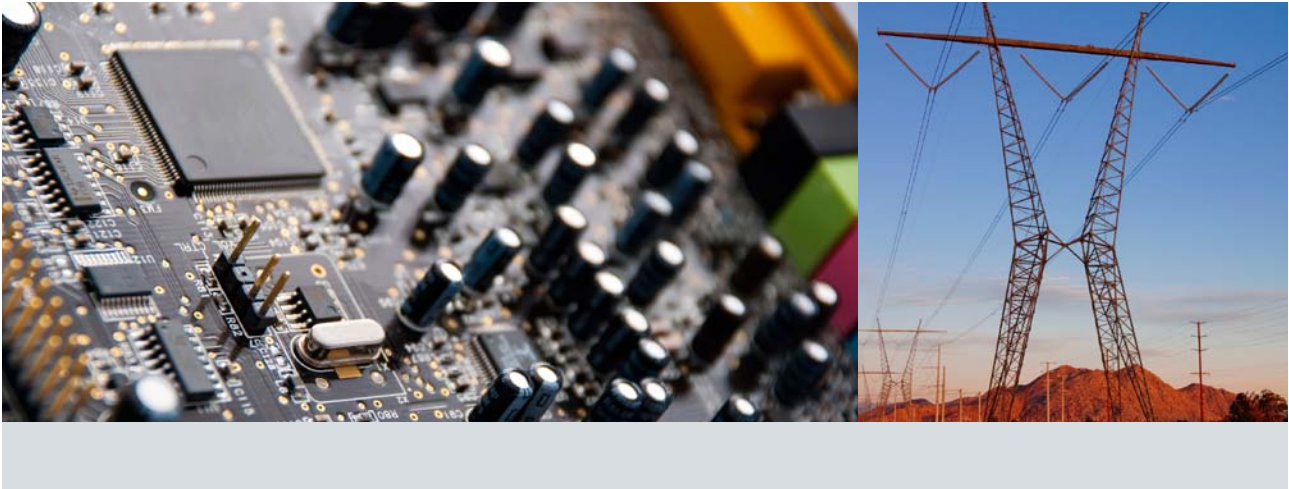
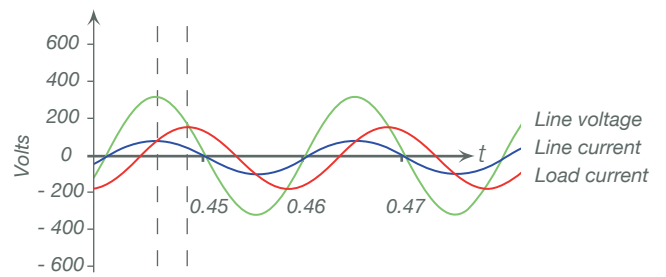

Fig.1b – Supply voltage and superimposed line and load currents without PFC [1]

Fig.1c - Supply voltage and line and load currents with PFC [1]

Closing switch S1 and connecting capacitor C1 in Fig. 1a produces the oscillogram of Fig. 1c in which the terminal voltage is restored to 230VRMS and the load current is 122ARMS. The load voltage is shifted by about 54° from the load current (PF = 0.59) but the line current (lower green trace) is perfectly in phase with the terminal voltage. The supply now views the load as operating at unity PF because capacitor C1 has been chosen so as to draw enough leading current to compensate the inherently lagging current of the load.



Thus the line-current (lower green trace) is exactly in phase with the supply voltage (phase-shift = 0°) and the PF at the load terminals is unity. As a consequence, only 66ARMS are drawn from the supply as opposed to the 108ARMS drawn in the previous, uncompensated case. The line is loaded with 60% less current and the load voltage does not sag. The load power is now:  $230V \times 122A \times 0.59 = 16.6kW$  per its 230V rating as opposed to 30% lower in the uncompensated case.

Thus it can be seen that the addition of PFC not only corrects the power factor but also restores the load voltage level to that of the supply. As we will see later, it can also have a beneficial filtering function and reduce harmonic distortions.

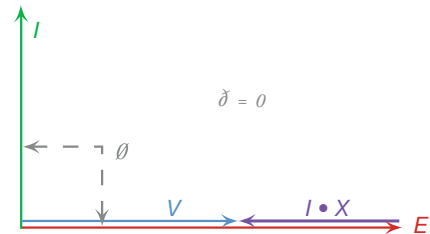
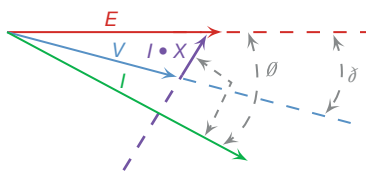
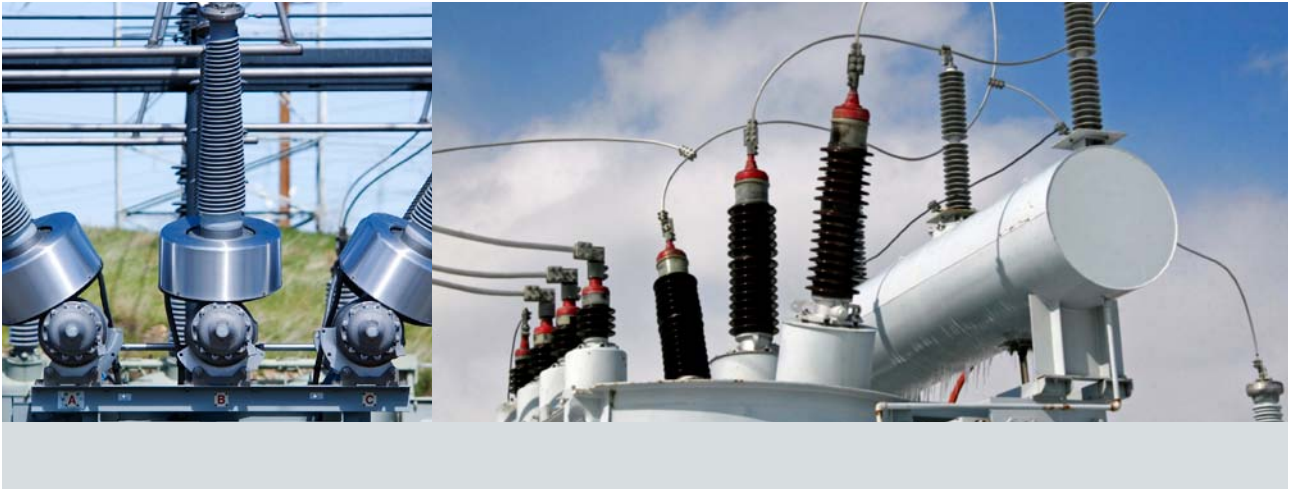

**VAR Compensation Methods**

There are different approaches to PFC and their salient techniques are described next.

**Synchronous Condenser (SC)**

An early method of PFC was to use synchronous machine which can be used as either generators or motors, depending on the direction of torque. When the torque is zero, the machine can be so excited that the terminal voltage is exactly equal to the machine EMF (electro-motive force) and no current flows. By over, or under-exciting the machine, current flows, limited by the machine’s reactance, i.e. in quadrature with the terminal voltage and EMF.

The operation of the synchronous generator (SG) and the Synchronous Condenser (SC) is illustrated by the vector diagrams of Figs 2a and b respectively where E is the machine EMF, X is the machine reactance, I is the current, V is the terminal or line voltage and  $\delta$  the torque-dependent angle between E and V.

Fig. 2a - SG vector diagram

Fig. 2b - SC vector diagram

With a purely inductive coupling between the “terminals” of E and V, the 90° shifted current produces a boosting or bucking voltage  $I \cdot X$  as seen in Fig.2b for the case of an over-excited machine ( $E > V$ ) producing leading current. An under-excited machine is represented by a similar diagram but with  $V > E$  and I in the opposite direction, i.e. lagging current.

The SC therefore fulfils the same functions as the capacitor (“condenser”) of Fig. 1 (from which it derives its name and from which, in turn, all non-rotating solutions derive the term “static” in their appellation). It acts both as a VAR compensator and voltage regulator but unlike the capacitor, it cannot contribute to harmonic filtering in distorted networks. These systems are rarely installed today because of their cost, noise/vibration and maintenance requirements.



**Switched Capacitor Banks (SCB)**

This is the simplest PFC approach whereby capacitors are switched across the line to provide leading current which cancels the naturally lagging network or load current, as introduced in Fig. 1a and shown in Fig. 3.

The system power factor is monitored and when it deviates too far from unity (let's say, it falls below 0.95) capacitors are switched in, typically via contactors as shown in Fig.3. This type of compensation suffers from the following limitations:

- to minimise the number of capacitors and contactors, only a few discrete capacitance values are switched so that accurate compensation is not possible
- the capacitors appear across the line without regard to existing line harmonics which may then resonate and produce excessive capacitor currents and increase the harmonic currents in the system
- the step-function application of capacitive loads produces current and voltage transients and corresponding voltage fluctuations
- there are other capacitor banks within a network (probably doing the same job further along the network) which will have been designed to not resonate at the fundamental and other prevalent frequencies: adding different capacitive values will change this situation, potentially leading to resonance effects that had been previously avoided

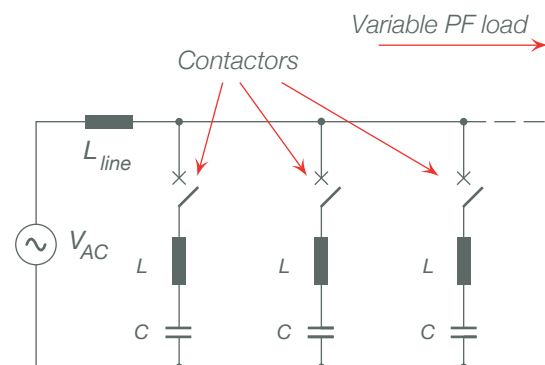
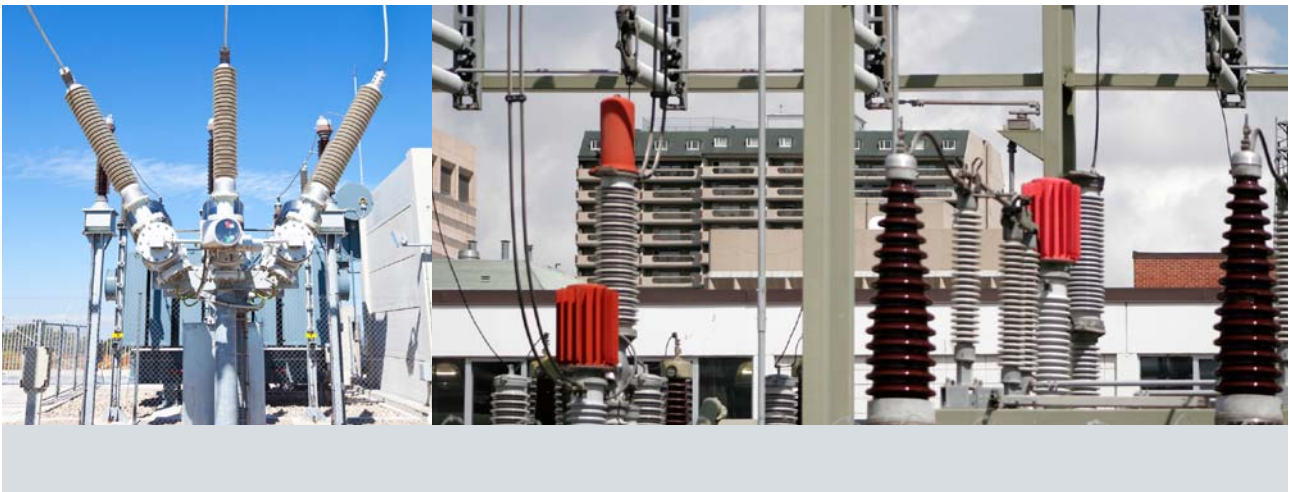

Fig. 3 – Switched capacitor compensation

- the system cannot compensate for leading reactive power
- the response time is of the order of tens of milliseconds
- the capacitors are usually decoupled by inductors to act as filters to avoid resonance with the principal harmonics (“de-tuning”); these inductors also serve to limit the capacitor inrush currents which would tend to “spot weld” the switch contacts, however, on opening, these contacts inevitably draw inductive arcs which also degrade the contacts making them subject to failure or at least frequent maintenance



**Thyristor Switched Capacitors (TSC)**

The arcing problems of the last point can be solved by replacing the contactors by anti-parallel thyristor pairs which additionally reduces response time to a half period of line frequency.

This however does not solve any of the other problems and increases capital costs while nevertheless reducing maintenance costs and increasing reliability.

**Switched Capacitors (SCB) and Thyristor Controlled Rectors (TCR)**

This configuration is a considerable improvement on the basic system of switched capacitors. The capacitors are still switched (mechanically or by thyristors), providing “rough” PF correction but additionally, a parallel-connected reactance is “phased” in and out to control the amount of lagging power added to the system.

By adding continuously variable lagging power, the PF can be finely regulated after each new capacitance has been switched in or out. See Fig. 4.

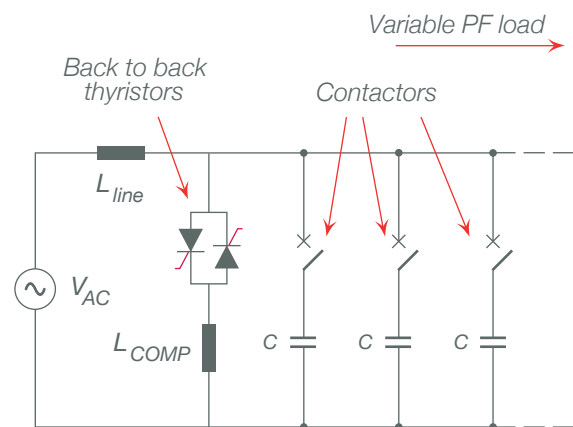

Fig. 4 - Thyristors used in AC phase control to finely adjust lagging PF after coarse compensation changes by capacitor-switching, in a conventional SVC

Thus the frequency of switching in and out capacitor banks is reduced which decreases the contactor wear in SCBs and minimises the number of transients.

TCRs coupled with TSCs have response times of half a line frequency period. With this kind of compensation, switching transients and contactor wear are minimised.

Nevertheless, the fact that the overall capacitance is changed when switching banks in and out means that there is always the possibility of unexpected resonances occurring.

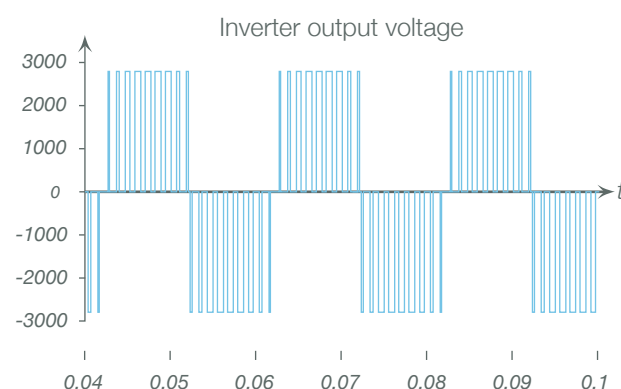
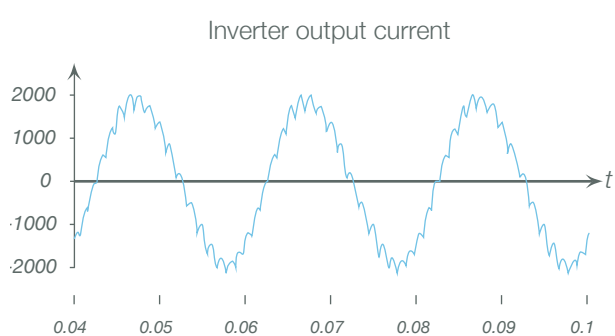

Fig. 5 – PWM STATCOM waveforms

**STATCOMs**

These are the latest generation of PFC systems. They operate on the same principles as the synchronous condenser but instead of using a rotating machine, a voltage-source converter is used.

In one of its simplest forms, the STATCOM consists of a pulse width modulated (PWM) inverter which synthesises a sinusoidal voltage from a DC source according to the waveform of Fig. 5.

Changing the mark-space ratio of the inverter output changes the amplitude of (the fundamental of) E in Fig. 2b. Depending on the PWM frequency, these changes in E can be very fast, making the STATCOM the fastest form of compensation available today. With a high PWM frequency, the STATCOM can also synthesise harmonics and can also fulfil the filtering function of conventional SVCs.

Unfortunately, to achieve all this functionality requires sophisticated inverter technology and the greater costs and losses which it occasions have limited the general use of STATCOMs to-date.

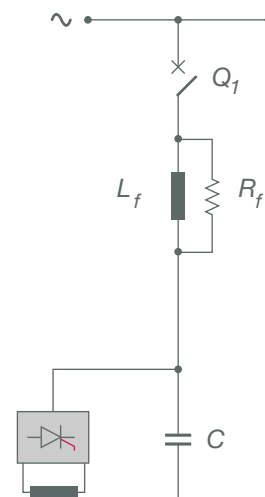
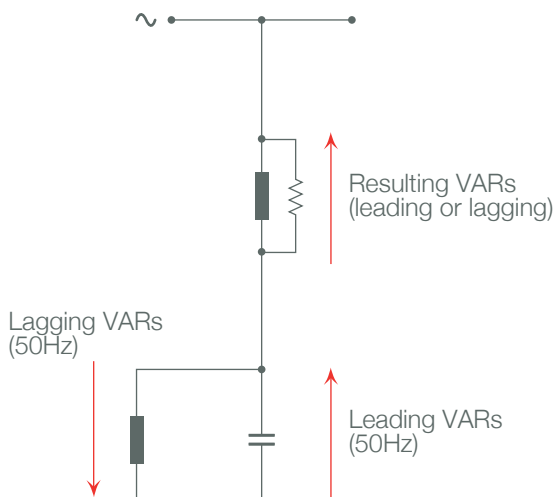

Fig. 6a - Power flow representation of the APR circuit  
 Fig. 6b - Single phase equivalent representation of APR circuit

**Thycon Active Power Factor Regulator (APR)**

The Thycon APR takes the concept of minimal system perturbation, one step further.

Here the compensating capacitor bank is fixed and is never switched in or out but is sized to compensate for the worst possible lagging PF. The compensating 6-pulse (or higher) Graetz Bridge is sized to fully compensate the installed capacitance so that when the network is unloaded, it sees no contribution from the APR. A lagging PF is then compensated by reducing the APR's internal lagging power and injecting leading power to the network.

Conversely, a leading power factor is compensated by increasing the APR's lagging power, resulting in a net injection of lagging power to the network. This is illustrated in Fig. 6a.

The process occurs seamlessly over the full specified range from leading to lagging power. There are no system perturbations from capacitor switching and there are no mechanical wear-out effects. An advantage of using a Graetz Bridge is shorter response time (1.66ms).



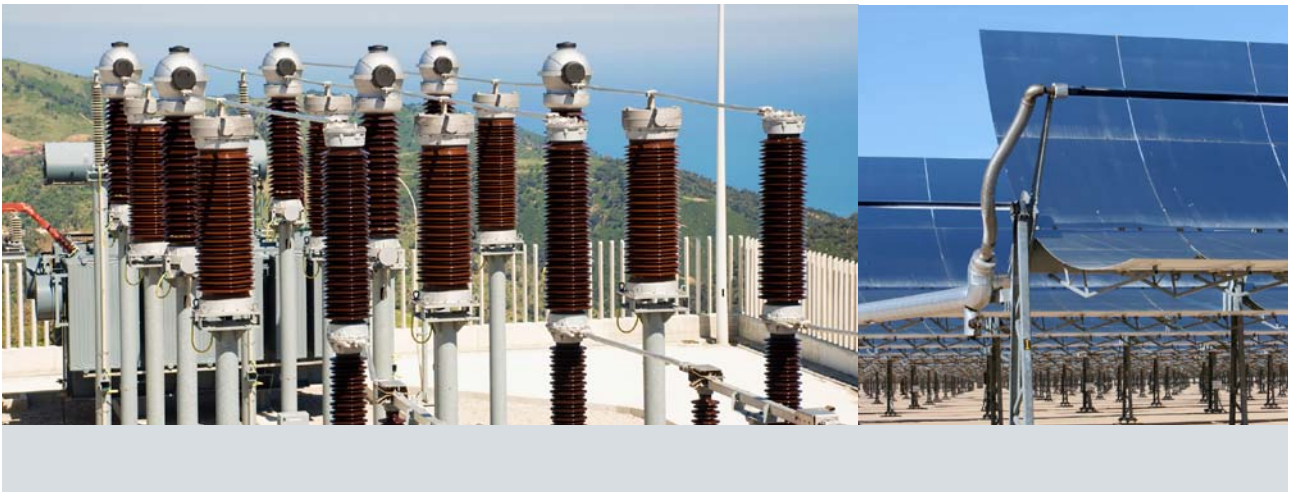

Mains supply voltage and current without an APR, THVD: 8%, THID: 11%

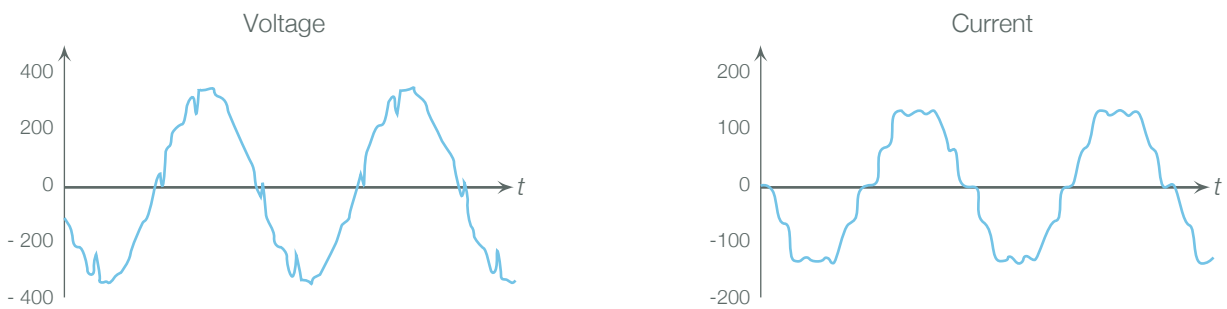

Mains supply voltage and current with an APR, THVD: 1%, THID: 6%

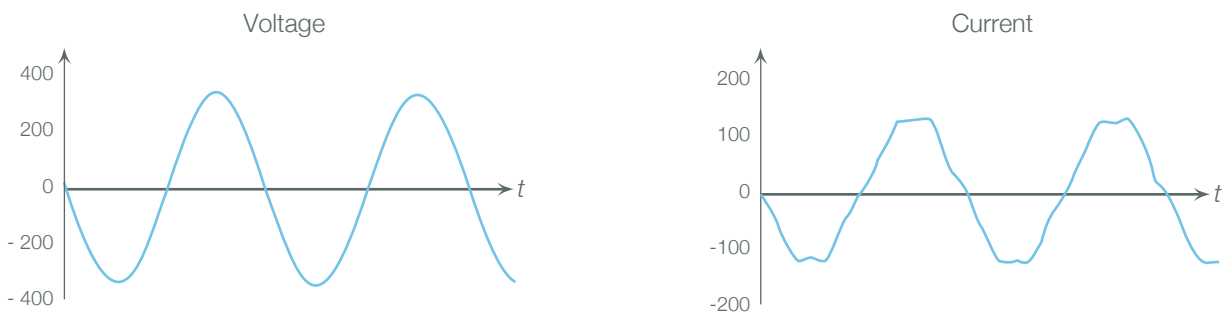

Fig. 7a and 7b - AC network voltage and current waveforms before and after connection of APR

The mechanical switch, Q1, is present only for fault protection and system isolation and are not subject to wear. Readings of typical network current and voltage waveforms are shown in Fig. 7 : the top two

traces show supply voltage and current prior to connection of the APR and the bottom two, after connection of the APR. Not only is the power factor corrected but it can be seen that the total harmonic distortion (THD) of both voltage and current are significantly improved.

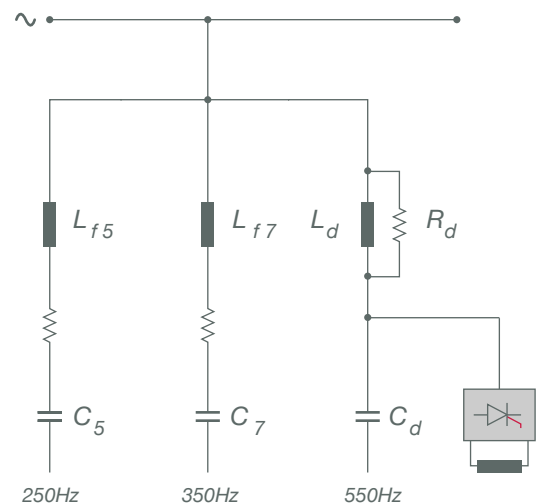
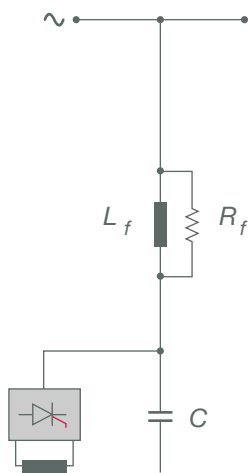

Fig. 8a - Single phase equivalent representation of APD circuit - a single damped branch

Fig. 8b - Single phase equivalent representation of APD circuit - multiple tuned branches plus a damped branch

**Harmonic attenuation**

In general, harmonics present on the network, are attenuated by filters of the type shown in Fig. 8. The fixed capacitor bank is a constant 50Hz reactive power generator while the thyristor bridge can be considered variable 50Hz reactive power absorbers.

To analyse the harmonic conditions (i.e. for non-50Hz conditions) therefore, the thyristor bridge is neglected as it is present only to absorb 50Hz reactive power. The single-phase equivalent circuit for 50Hz analysis is shown in Fig 9a.

While many filter topologies are possible, the most common circuit used in Thycon APD is a second-order damped filter. This circuit offers low impedance to a broad range of frequencies and will be analysed further here.

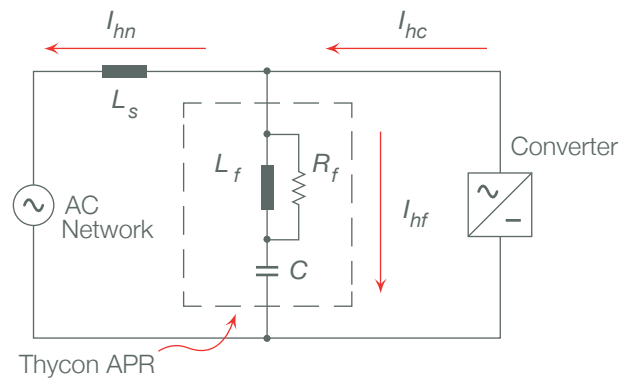
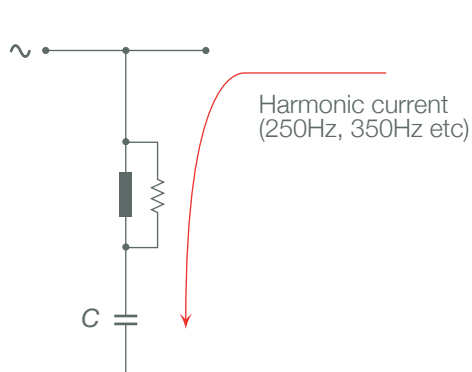

By connecting the filter in shunt between phases, an alternative path for harmonics is provided that would otherwise be transmitted to the grid. The amount of attenuation depends on the admittance the filter provides at each frequency, which depends on the circuit elements (capacitor, inductor and resistor) chosen for the filter design. If the grid impedance and harmonic currents are known, an accurate calculation can be made of the resulting total harmonic current distortion (THID) in the grid.

Fig. 9b, represents the filter branches connected to the grid for which the following equations apply:

- impedance of series filter inductance for harmonic order n

$$Z_L(n) = j\omega Lfn$$

- impedance of series filter capacitor to harmonic order n

$$Z_C(n) = \frac{1}{j\omega Cn}$$

Fig.9a - Single phase equivalent representation of APR circuit for harmonic analysis

Fig.9b - Circuit for compensation of harmonic currents on the AC side of a converter

The filter impedance is given by:

$$Z_{filter}(n) = \frac{R_f \cdot Z_L(n)}{R_f + Z_L(n)} + Z_C(n) \quad [1]$$

The network impedance is:

$$Z_s(n) = j\omega Lsn \quad [2]$$

The harmonic current transmitted to the network  $I_{hn}$  is in the ratio of the two impedances from Eqns 1 & 2:

$$T_x(n) = \frac{Z_{filter}(n)}{Z_s(n) + Z_{filter}(n)} \quad [3]$$

$$I_{hn}(n) = I_{hc}(n) \cdot T_x(n)$$



where:  $n$  - is the harmonic order  
 $R_f$  - the filter damping resistance  
 $L_f$  - is the filter inductance  
 $Z_f$  - the filter impedance  
 $Z_c$  - the capacitor bank impedance  
 $\omega = 2\pi F$  with  $F$  the line frequency.

TX is represented in Fig. 10 as a function of  $n$ .

The filter is tuned near the 5th harmonic (250Hz) since this is usually the prevailing lowest order harmonic. The filter attenuates from the 5th harmonic up to and beyond the 49th (not shown). As can be seen, the 5th harmonic is almost completely eliminated and higher order harmonics are halved, hence the resulting THID is reduced by more than half.

It should be noted that any level of target THID set by the client can be achieved by the APR. The amount of harmonic attenuation obtained for a given site is influenced by the circuit parameters chosen – as can be seen from Eqn 3 where TX depends on the capacitor bank size and AC network impedance.

The APR capacitor bank is usually sized according to the PFC needs for the site or according to the harmonic attenuation needs, depending on which is more important for the application.

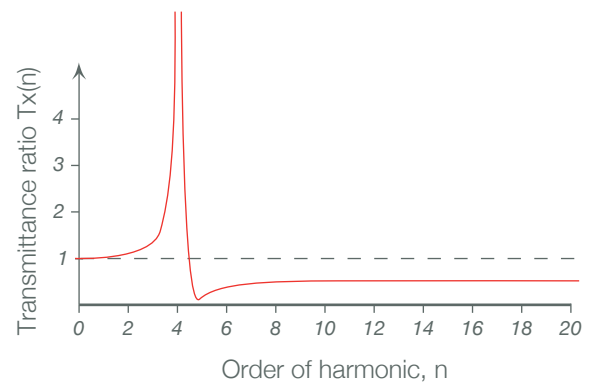
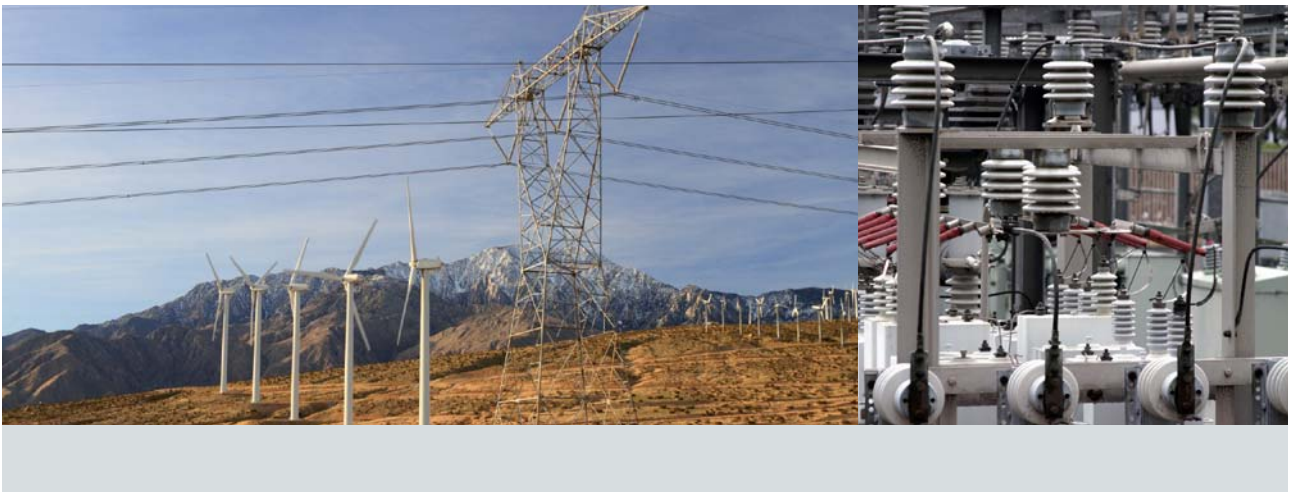

Fig. 10 – Transmittance of harmonics of order  $n$  into the AC network

The APR has no switching elements in series with the capacitor bank, ensuring the amount of capacitance and level of harmonic attenuation remains constant regardless of load size or power factor. As stated earlier, in addition to seamless power factor correction, the APR provides harmonic attenuation. Thycon engineers assess each site to determine which circuit is most suited (Fig. 7a or b) to reduce the harmonic distortion below the level of the client’s target THID.

The level of filtered harmonics of a fixed capacitor APR does not hinder its ability to provide reactive power; the performance of these two features being totally independent. It should be mentioned that in addition to harmonic filtering, the APR attenuates voltage notches at the PCC of an AC network.



**Load Balancing**

APRs are capable of (more or less concurrently) regulating voltage and power factor as well as balancing system currents and voltages. In Load Compensation the objective is to transform the current drawn by an unbalanced and generally non-unity power-factor load into a balanced set of line currents.

The principles by which this can be done were outlined in a seminal paper from the Westinghouse Electric Corporation in 1978 [2] in which it was shown that any dissimilar three-phase load-impedances, Z, can be represented by corresponding admittances, Y.

An admittance such as  $Y_{ab}$ , connected between two phases, may be composed of a conductance (G) and a susceptance (B), such that:

$$Y_{ab} = G_{ab} + jB_{ab}$$

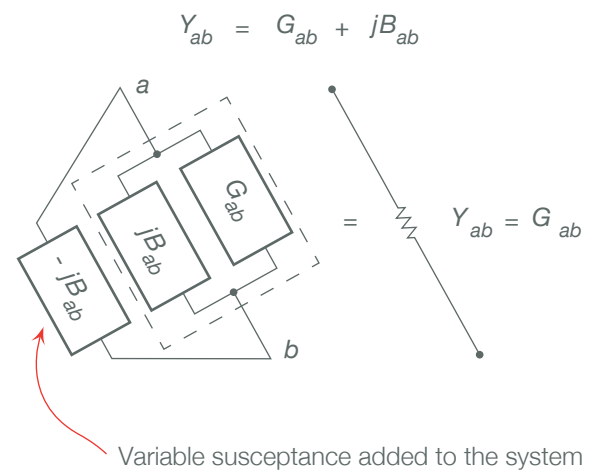

Fig. 11 – Compensation of susceptance

The susceptance can be cancelled by an appropriate compensating susceptance,  $-B_{ab}$ , connected in parallel with  $Y_{ab}$  resulting in a pure conductance  $G_{ab}$ , as illustrated in Figure 11.

For arbitrary, time-varying, unbalanced loads, an APR can act as a variable susceptance, eliminating the negative sequence current components generated by the unbalanced load, leaving the AC network to supply only positive sequence load current.



Variable susceptances added to the system by the APR

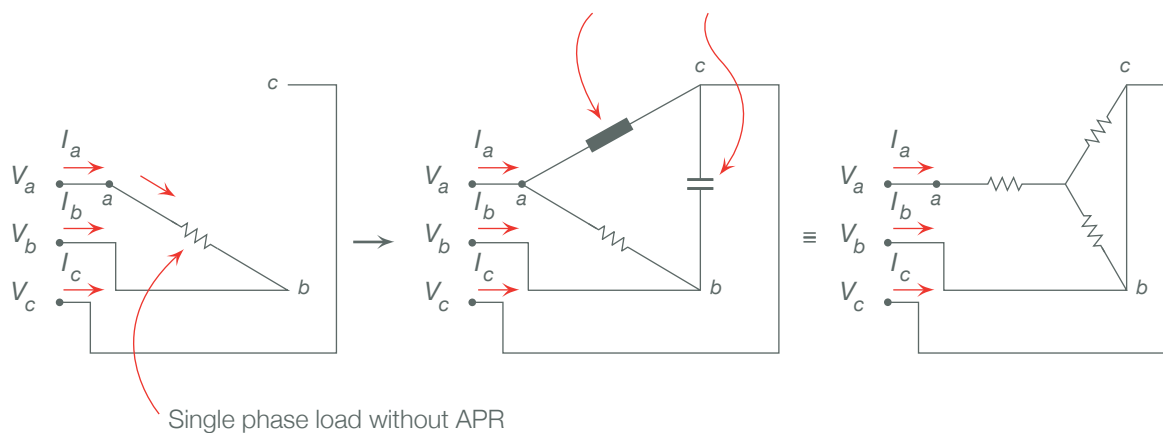

Single phase load without APR

The principle described above can be extended to any degree of imbalance and includes the rebalancing of single-phase loads connected across two of the three phases as sometimes used where a traction catenary is supplied from a three-phase utility, shown in Fig. 12.

The Thycon APR can simultaneously load-balance and compensate power factor, resulting in balanced currents and unity PF on the AC network. PFC and load-balancing is of particular use in industrial plants such as arc furnaces and rolling mills where the loads are localised.

Fig. 12 – *Balancing of a single-phase resistive load by a capacitive and an inductive susceptance*

**Voltage Compensation**

In transmission networks more importance may be attached to the stabilisation and restoration of voltage at various nodes of the network without regard to concern for the power-factor at the node.

The same technology is used here but with different algorithms to ensure that maximal power can be transmitted and to damp voltage oscillations provoked by sub-synchronous resonance.



## Applications

PFC is required wherever the load current is not in phase with the source voltage which, in effect, means that it is required everywhere since most loads (e.g. motors), sources (e.g. generators) and transmission lines are inductive.

The compensation of transmission lines is generally left to the transmission authorities, though in the cases of railways, mines and heavy industries, these may be partly or fully owned by the consumer himself.

Most industrial sites are responsible for ensuring a high PF, stable voltage and low harmonic distortion where their own large, inductive and non-linear loads are the cause of degraded PQ.

A non-exhaustive list of applications requiring PFC in one form or another is shown here:

- weak distribution grids
- unbalanced loads
- arc furnaces
- wind farms
- wood chippers
- welding machines
- car crushers & shredders
- steel mills
- mineral (mining) grinders
- mining shovels & hoists
- harbor cranes
- oil pipe-lines
- high current rectifiers
- traction lines and sub-stations
- industries with fast changing & non-linear loads
- hospitals and other medical centers
- data/server centers
- extrusion plants
- office buildings
- electrolysis plants
- water treatment plants and pumping stations.
- A few of these are worthy of particular mention:



### Wind mills and wind farms

Power from wind-farms represents a growing percentage of national generation in certain countries (e.g. >40% in Sweden). Wind-farms have thus become significant contributors to national grids and are increasingly subject to the same “grid codes” as conventional power stations.

Early wind-farms used induction generators which operate at a lagging power factor. These are directly connected to the grid without electronic torque control other than via mechanical turbine pitch and stall. Later systems used wound-rotor induction machines with slip-ring-connected resistors which allowed some speed fluctuations up to +/-5%. None of these systems allow PFC unless they are fitted with compensating capacitors (e.g. SCBs).

Today, the most commonly used approach is the doubly-fed induction generator (DFIG) with an electronic speed controller supplying the rotor. The inverter rating of the DFIG solution is 30% of the turbine rating which explains its cost-effectiveness and popularity. These systems allow +/- 30% speed variation and some PFC control but not enough voltage support to fulfil recent low-voltage ride-through requirements (LVRT). Whereas, wind-turbines were formerly allowed to disconnect from the grid in case of a line fault, they are now required to remain connected and feed the fault until it clears. This requires the retrofitting of shunt-connected compensation to support the turbine output, either individually on each turbine or collectively at the farm output.

However, even if the power factor at the individual turbines is kept constant as real power varies, the reactive power consumption of the wind farm as a whole will continue to vary as a result of reactance in the collection system so that reactive power consumption generally increases with real power output unless ancillary reactive support equipment is installed [3].



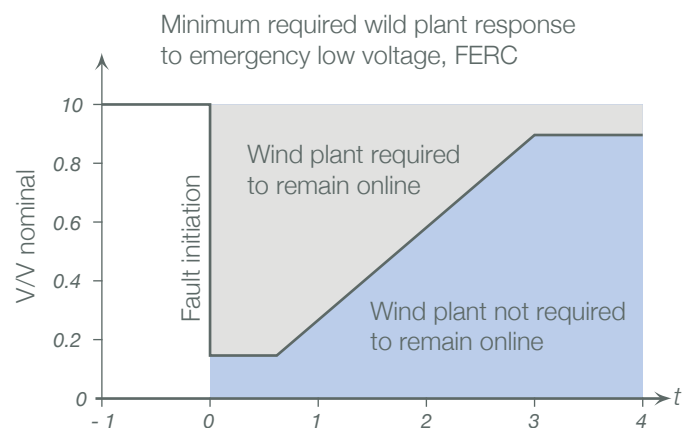

Fig. 13 – FERC Ride-through requirements

Requiring the wind-farm to hold a reasonably constant transmission voltage, even as the output of the wind-farm changes, is one of the main goals of FERC (the US Federal Energy Regulatory Commission) Order 661-A. The order requires that wind-farms operate with a power factor that is variable between 0.95 lagging and 0.95 leading at the high side of the wind-farm main transformer.

FERC Order 661-A further requires that the wind farm remain in service during any three-phase fault that is cleared by the line protection without electrically separating the wind farm from the transmission system provided the fault does not depress the voltage at the Point of Common Coupling (PCC) below 0.15 p.u. (15% of normal voltage) as shown in Fig. 13.

By requiring this level of reactive power control, FERC is ensuring that wind-farms will minimise system voltage variations and thus reduce any negative impact of the wind farm on the transmission grid.



Other countries such as Germany and Spain have implemented somewhat different LVRT profiles but the FERC code roughly envelopes them. Such grid codes necessitate special reactive support generally beyond that which can be provided by the individual wind turbines.

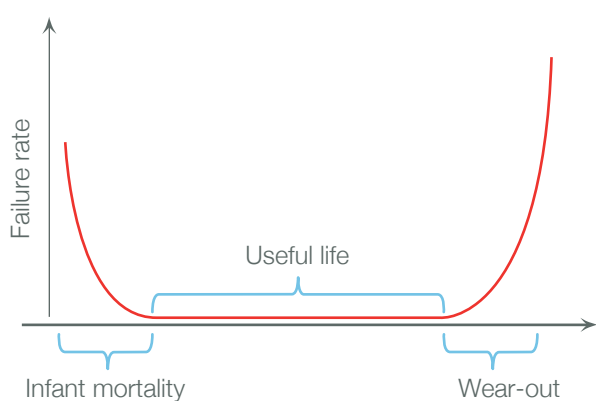

Fig. 14 - Reliability “bath-tub” curve

**Electric Arc Furnaces (EAF)**

These large power consumers are a source of all the perturbations known in PQ:

- low power factor especially prior to striking when the electrodes are shorted to the scrap
- flicker as the arcs vary during melting of the scrap (5 – 15Hz)
- harmonic distortion since the arc is a non-linear load
- voltage sag due to the large powers drawn (100MW)
- reduced power transfer due to voltage sag
- unbalanced phase voltages (electrodes do not strike simultaneously)
- network oscillations.

The disturbances from the arc furnace are transferred to other users of the grid via the PCC. The voltage fluctuations causing flicker are then spread throughout the grid from the PCC with little damping.

The motivations for the EAF operator to install PFC are several:

- increased production capacity
- reduced energy consumption per unit weight of steel
- reduced electrode wear
- no reactive-power penalties.

**Reliability**

Reliability is a measure and prediction of failure rates. Failure mechanisms are various but they fall into three well-defined categories: infant mortality, useful life and wear-out as depicted in Fig. 14, which is commonly known as the “bath-tub” curve.

The causes of component failure may be intrinsic or extrinsic. Intrinsic failures are related to component manufacturing defects and therefore usually occur in operation that is within the device’s specification.

Extrinsic failures are provoked by external causes (such as the lightning strikes) or overloads which take the device outside of its specification. Their nature may be electrical, mechanical or thermal.



Infant mortality may be either intrinsic or extrinsic, resulting from component manufacturing defects or poor assembly, commissioning, installation and start-up problems. They are little related to time and are measured in defects per million (DPM). By contrast, the wear-out failures are typically measured in number of operating cycles, e.g. temperature, power or switching cycles.

The useful life of a device is that portion of its life where a low and constant failure rate occurs, typically of external origin. It should be the most important part of the curve since it determines the mean-time between failures (MTBF). The useful life of a device is expressed in FITs (failures-in-time in number of failures per 10<sup>9</sup> device-operating hours) and is designated by the symbol  $\lambda$  in reliability engineering. MTBF is the reciprocal of failure rate and is given simply by  $1/\lambda$  in hours. Thus, a thyristor with a FIT rate of 100 (= 10<sup>-7</sup>) would have an MTBF of 10 million hours or 1'141 years, based purely on the constant random failure rate of the useful life.

Some components (such as ordinary incandescent light bulbs) have a low failure rate during a short (500hrs) useful life and a rapidly increasing rate thereafter. Solid -state devices (semiconductors) such as the thyristors used in TCRs, have an extremely long useful life of 20 to 30 years and a very low random failure rate.

### Thycon PFC Solutions

Thycon APRs are designed to meet the following criteria:

- seamless and accurate PFC
- lagging and leading compensation
- fixed capacitor bank means no capacitor switching
- no wear-out mechanisms
- no voltage spikes due to switching transients
- no step-changes in PF
- de-tuned capacitor bank means no harmonic resonance with the supply
- constant harmonic attenuation spectrum, regardless of load PF (Eqn 3)
- positive sequence, three-phase voltage regulation and PFC
- negative sequence voltage elimination
- improved load balancing
- faster response time (as little as 1.66ms); rapid insertion of VARs into the line at the instant of load change, mitigating voltage sags and no risk of overvoltage at the supply bus
- shunt-connected resistor across de-tuning reactors to eliminate notching
- flicker reduction
- improved system damping and transient stability
- retrofit-enabled for up-grading existing TSC or SC sites.



### **Costs**

While the solution of switched capacitor banks undoubtedly offers the lowest installation costs, the life-cycle costs are actually the highest. This is because, only “rough” compensation can be achieved with switched capacitors and where penalties are applied for power factors other than unity, these charges will accumulate over time. Even suppliers who do not currently apply penalties within certain PF limits may have to change their policies in the future as grids are called upon to handle ever-higher power densities and distribution standards are tightened.

Contactor-based solutions require regular maintenance and the finer the compensation must be, the higher the number of switched banks and hence, the higher the failure rate and maintenance requirements. These costs must also be factored into the overall capital and life-cycle costs and the targeted life should normally be > 20years (which can only be achieved through solid-state technology.

### **Advanced Control and Supervisory Systems**

Smart digital signal processing provides control and power factor regulation of the Thycon APR. The control is automatic, continuous and linear about the set-point selected by the user.

PF control is inherently fast and allows seamless regulation throughout the operating range, eliminating the typical switching effects of traditional power factor regulation methods.

Thycon APRs can be controlled and monitored from the unit itself or remotely via serial, TCP/IP, SCADA or DNP3. The system is totally automatic and does not require manual restarting for fault-initiated supply disturbances.

A simple control and status interface is provided with Start and Stop push-buttons for activating the equipment with ON LEDs indicating that mains power is available and that the APR is on-line.



The APR system monitor is a smart LCD panel featuring a simple user interface that incorporates advanced diagnostic facilities enabling immediate access to:

- power monitoring - voltage/current/kW/kVA/power factor/harmonic distortion
- operating status and alarms
- event history
- password protection for user-defined settings
- service control and test options

The system monitor stores the last 200 system events in a non-volatile information buffer for fast fault diagnosis and status indication even after a re-start or a complete power outage.

### **Conclusions**

All the currently available PFC techniques have been described in this paper.

The Thycon APR offers the highest performance / life-cycle-cost combinations as well as the highest reliability of any PFC equipment available today. Thycon has 30 years of experience with these mature and proven technologies which play a growing role in today's PQ-conscious environment.

### **References**

- [1] Simulations made with PLECS 3.0.3 = [www.plexim.com](http://www.plexim.com)
- [2] Principles and applications of static, thyristor-controlled shunt compensators, L.Gyugyi, R.A.Otto, T.H.Putman, IEEE Transactions on Power Apparatus and Systems, Vol. PAS-97, No. 5, Sept/Oct 1978
- [3] Wind Generation Presents Interconnection Challenges, Michael Ross, North American WINDPOWER, February 2006 issue

# THYCON

THYCON INDUSTRIAL PTY LTD  
20 AUDREY AVE COBURG  
3058 VIC AUSTRALIA  
PH 61 3 9319 9000  
FAX 61 3 9319 9001  
ABN 17 068 011 049  
EMAIL [info@thycon.com.au](mailto:info@thycon.com.au)  
WEB [www.thycon.com.au](http://www.thycon.com.au)  
24-HOUR SERVICE 1800 670 700

